



Abresan Toloue Mehr Company
Producer of valves and under pressure joints

DUCTILE CAST IRON JOINTS



۶۶۶۲۸۴۴۹۵ م



OHSAS 18001



ISO 14001



ISO 9001: 2008



www.atmehr.com

Ductile cast iron joints under pressure

Application of connections (joints)

Fittings for ductile cast iron pipe - Pipes PE- GRP pipes - Zip tube - UPVC pipes. It is used for fluids like raw water, drinking water and sewage. And is used in the transfer port as an installation of the branching of the various valves (butterfly, pressure switch, slider, etc.) between the pipe and the direction of deviation of the pipe angle.

Size: DN 2000 DN 50

Pressure: PN6-PN10-PN16- PN25

Specifications of ductile cast iron joints

Designed in accordance with ISO3732-DIN EN 545- ISO 2531

Drilling of flanges according to ISO9005-2 is equivalent to DIN EN1092-2, DIN2501

Covering the use of bitumen with the standard ISO8179 production under standard conditions

Joints Packing

Joints are usually arranged in bulk and packed on a truck or other vehicle. On customer request, the joints can be packed in wooden boxes or on pallets.

Joints layout

Depending on the type and size of the connections, they can be done in both vertical and network mode

How to install and assemble:

Flanged Joints

The flanges of the pipes that the fittings need to be installed in parallel are in the same direction. To connect the flanges and screws alike and tight.

Flower connections

To install the glider fittings to the front edge of the glove and to clean the inner surfaces of the head In the meantime, the end of the tube ascites or aschat flowers should be clean at least 20 cm with a spatula and excavation around the rectum where the bulb is located in the direction of the tool during the closing of the bolts and nuts, the ease of sealing operations at the junction, The soil of these areas should be 40 to 60 cm in length and at least 40 cm in depth.

Titanic connections

1. Cleaning operation: Rubber washers, especially the grooves, should be cleaned. In order to clean inside the bowls, especially the grooves for the rubber gasket. Additionally, the ends of the pipe should be cleaned from the edge of the tops to the lines of the symbols of the assembly with a spatula.

2. Lubrication of slings: For ease and installation of the gasket in the grooves, the groove of the seating area should be lubricated with a suitable lubricant and be careful not to place the groove on the heel of the drill.

3. Gasket insertion: To insert rubberized rubber gasket, create one in the shape shown below, then we gradually fit it into the groove. at the end, the folded portion is tapped into the groove.

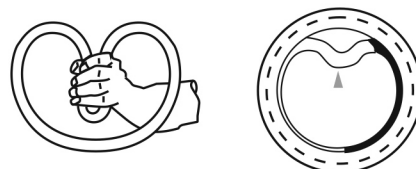

WELDED-ON FLANGE (PN 10)

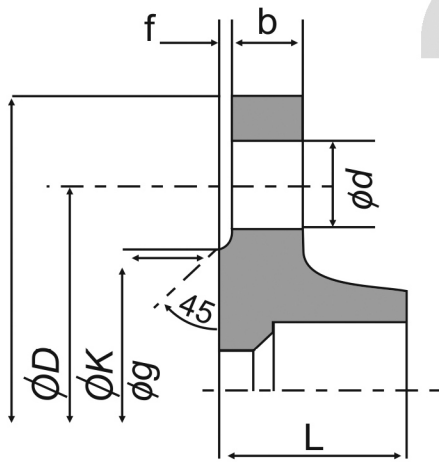

DN	D	K	g	b	f	L	Bolt & Holes		
							size	d	No.
50	165	125	99	14	3	35	M16	19	4
60	185	145	108	14	3	40	M16	19	4
65	185	145	118	19	3	40	M16	19	4
80	200	160	132	16	3	43	M16	19	8
100	220	180	156	16	3	45	M16	19	8
150	285	240	211	16	3	50	M20	23	8
200	340	295	266	17	3	55	M20	23	8
250	400	350	319	19	3	60	M20	23	12
300	455	400	370	20.5	4	65	M20	23	12
350	520	460	429	22.5	4	70	M20	23	16
400	580	515	480	24	4	75	M24	28	16
500	715	620	582	27.5	4	85	M24	28	20
600	840	725	682	31	5	95	M27	31	20
700	910	840	794	34.5	5	105	M27	31	24
800	1025	950	901	38	5	115	M30	34	24
900	1125	1050	1001	41.5	5	125	M30	34	28
1000	1255	1160	1112	45	5	135	M33	37	28
1100	1355	1270	1212	48.5	5	145	M33	37	32
1200	1485	1380	1328	52	5	155	M36	41	32
1400	1685	1590	1530	55	5	175	M39	44	36
1500	1820	1700	1640	57.5	5	185	M39	44	36
1600	1930	1820	1750	60	5	195	M45	50	40
1800	2130	2020	1950	65	5	215	M45	50	44
2000	2345	2230	2150	70	5	235	M45	50	48

Abresan Toloue Mehr Company reserves the right to change any dimension and specification to promote quality while considering related standards.

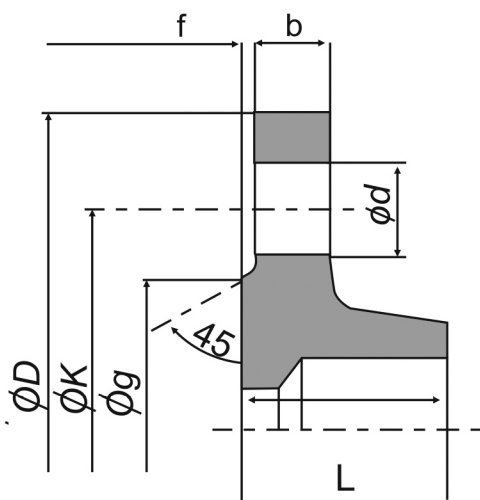

WELDED-ON FLANGE (PN 16)

DN	D	K	g	b	f	L	Bolt & Holes		
							size	d	No.
50	165	125	99	14	3	35	M16	19	4
60	185	145	108	14	3	40	M16	19	4
65	185	145	118	19	3	40	M16	19	4 or 8
80	200	160	132	16	3	43	M16	19	8
100	220	180	156	16	3	45	M16	19	8
150	285	240	211	16	3	50	M20	23	8
200	340	295	266	17	3	55	M20	23	12
250	400	355	319	19	3	60	M24	28	12
300	455	410	370	20.5	4	65	M24	28	12
350	520	470	429	22.5	4	70	M24	28	16
400	580	525	480	24	4	75	M27	31	16
500	715	650	609	27.5	4	85	M30	34	20
600	840	770	720	31	5	95	M33	37	20
700	910	840	794	34.5	5	105	M33	37	24
800	1025	950	901	38	5	115	M36	41	24
900	1125	1050	1001	41.5	5	125	M36	41	28
1000	1255	1170	1112	45	5	135	M39	44	28
1100	1355	1270	1212	48.5	5	145	M39	44	32
1200	1485	1390	1328	52	5	155	M45	50	32
1400	1685	1590	1530	55	5	175	M45	50	36
1500	1820	1710	1640	57.5	5	185	M52	57	36
1600	1930	1820	1750	60	5	195	M52	57	40
1800	2130	2020	1950	65	5	215	M52	57	44
2000	2345	2230	2150	70	5	235	M56	62	48

Abresan Toloue Mehr Company reserves the right to change any dimension and specification to promote quality while considering related standards.

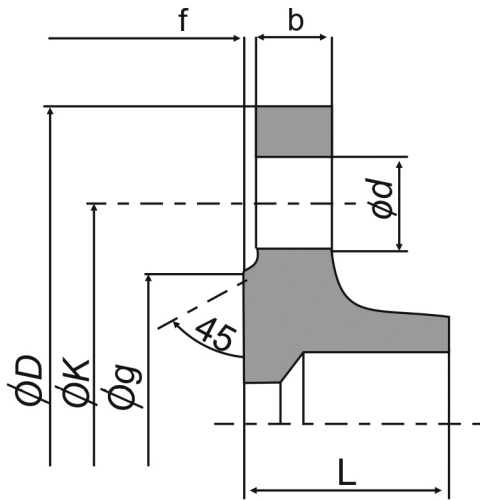

WELDED-ON FLANGE (PN 25)

DN	D	K	g	b	f	L	Bolt & Holes		
							size	d	No.
50	165	125	99	16	3	35	M16	19	4
60	185	145	108	16	3	40	M16	19	8
65	185	145	118	19	3	40	M16	19	8
80	200	160	132	16	3	43	M16	19	8
100	235	190	156	16	3	45	M20	23	8
150	300	250	211	17	3	50	M24	28	8
200	360	310	274	19	3	55	M24	28	12
250	425	370	330	21.5	3	60	M27	31	12
300	485	430	389	23.5	4	65	M27	31	16
350	555	490	448	26	4	70	M30	34	16
400	620	550	503	28	4	75	M33	37	16
500	730	660	609	32.5	4	85	M33	37	20
600	845	770	720	37	5	95	M36	41	20
700	960	875	820	41.5	5	105	M39	44	24
800	1085	990	928	46	5	115	M45	50	24
900	1185	1090	1028	50.5	5	125	M45	50	28
1000	1320	1210	1140	55	5	135	M52	57	28
1100	1420	1310	1245	59.5	5	145	M52	57	32
1200	1530	1420	1350	64	5	155	M52	57	32
1400	1755	1640	1560	69	5	175	M56	62	36
1500	1865	1750	1678	72.5	5	185	M56	62	36
1600	1975	1860	1780	76	5	195	M56	62	40
1800	2195	2070	1985	83	5	215	M64	70	44
2000	2425	2300	2210	90	5	235	M64	70	48

Abresan Toloue Mehr Company reserves the right to change any dimension and specification to promote quality while considering related standards.

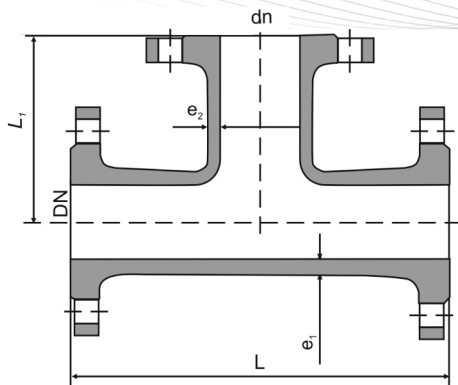

ALL FLANGED TEE

DnxDn	Body		Branch	
	e ₁	L	e ₂	L ₁
200x200	8,4	520	8.4	260
250x60	9	385	7	260
250x80	9	405	7	265
250x100	9	425	7,2	270
250x150	9	485	7,8	280
250x200	9	540	8,4	290
250x250	9	600	9	300
300x60	9,6	405	7	290
300x80	9,6	425	7	295
300x100	9,6	450	7,2	300
300x150	9,6	505	7,8	310
300x200	9,6	565	8,4	320
300x250	9,6	620	9	330
300x300	9,6	680	9,6	340
350x60	10,2	430	7	320
350x80	10,2	445	7	325
350x100	10,2	470	7,2	330
350x150	10,2	530	7,8	340
350x200	10,2	585	8,4	350
350x250	10,2	645	9	360
350x350	10,2	760	10,2	380
400x80	10,8	470	7	355
400x100	10,8	490	7,2	360
400x150	10,8	550	7,8	370
400x200	10,8	610	8,4	380
400x250	10,8	665	9	390
400x300	10,8	725	9,6	400

DnxDn	Body		Branch	
	e ₁	L	e ₂	L ₁
50x50	7	280	7	140
60x50	7	290	7	–
60x60	7	300	7	150
65x65	7	305	7	150
80x50	7	310	7	135
80x60	7	310	7	155
80x80	7	330	7	165
100x50	7,2	320	7	145
100x60	7,2	320	7	165
100x80	7,2	330	7	170
100x100	7,2	360	7,2	180
125x50	7,5	330	7	160
125x60	7,5	330	7	180
125x80	7,5	350	7	185
125x100	7,5	370	7,2	195
125x125	7,5	400	7,5	200
150x50	7,8	340	7	170
150x60	7,8	340	7	190
150x80	7,8	360	7	200
150x100	7,8	380	7,2	205
150x125	7,8	410	7,5	215
150x150	7,8	440	7,8	220
200x50	8,4	365	7	195
200x60	8,4	365	7	215
200x80	8,4	380	7	225
200x100	8,4	400	7,2	230
200x125	8,4	435	7,5	240
200x150	8,4	460	7,8	245

Abresan Toloue Mehr Company reserves the right to change any dimension and specification to promote quality while considering related standards.

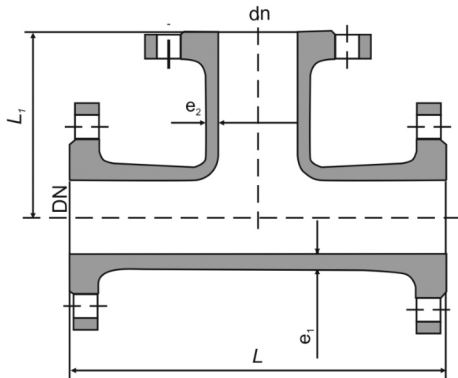

ALL FLANGED TEE

Dnxdn	Body		Branch	
	e ₁	L	e ₂	L ₁
1000x200	18	770	8,4	705
1000x400	18	990	10,8	735
1000x600	18	1650	13,2	765
1000x1000	18	1650	18	825
1100x400	19,2	980	8,4	795
1100x600	19,2	1210	13,2	825
1200x600	20,4	1240	13,2	885
1200x800	20,4	1470	15,6	915
1200x1000	20,4	1700	18	945
1400x600	22,8	1550	13,2	980
1400x800	22,8	1760	15,6	1010
1400x1000	22,8	2015	18	1040
1500x600	24	1575	13,2	1035
1500x1000	24	2040	18	1095
1600x600	25,2	1600	13,2	1090
1600x800	25,2	1835	15,6	1120
1600x1000	25,2	2065	18	1150
1600x1200	25,2	2300	20,4	1180
1800x600	27,6	1655	13,2	1200
1800x800	27,6	1885	15,6	1230
1800x1000	27,6	2120	18	1260
1800x1200	27,6	2350	20,4	1290
2000x600	30	1705	13,2	1310
2000x1000	30	2170	18	1370
2000x1400	30	2635	22,8	1430

Dnxdn	Body		Branch	
	e ₁	L	e ₂	L ₁
400x400	10,8	840	10,8	420
450x100	11,4	515	7,2	390
450x150	11,4	570	7,8	400
450x200	11,4	630	8,4	410
450x250	11,4	690	9	420
450x300	11,4	745	9,6	430
450x400	11,4	860	10,8	450
450x450	11,4	920	11,4	460
500x100	12	535	7,2	420
500x200	12	650	8,4	440
500x400	12	885	10,8	480
500x500	12	1000	12	500
600x200	13,2	700	8,4	500
600x400	13,2	930	10,8	540
600x600	13,2	1165	13,2	580
700x200	14,4	–	8,4	–
700x400	14,4	–	10,8	–
700x700	14,4	–	14,4	–
800x200	15,6	690	8,4	585
800x400	15,6	910	10,8	615
800x600	15,6	1350	13,2	645
800x800	15,6	1350	15,6	675
900x200	16,8	730	8,4	645
900x400	16,8	950	10,8	675
900x600	16,8	1500	13,2	705
900x900	16,8	1500	16,8	750

Abresan Toloue Mehr Company reserves the right to change any dimension and specification to promote quality while considering related standards.

DOUBLE FLANGED BEND

**DOUBLE FLANGED
BEND 11/25°**

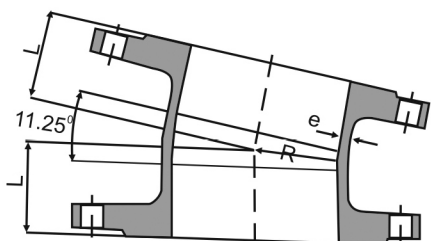

**DOUBLE FLANGED
BEND 22/5°**

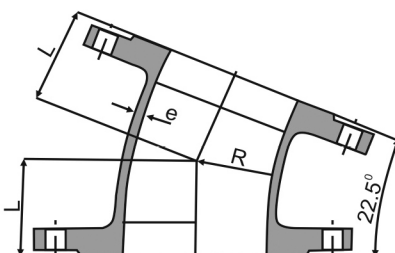

**DOUBLE FLANGED
BEND 45°**

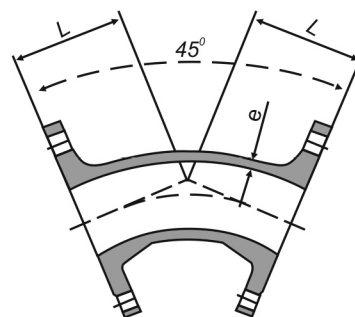

DN	e	L
50	7	80
60	7	85
80	7	90
100	7.2	95
150	7.8	95
200	8.4	100
250	9	105
300	9.6	105
350	10.2	150
400	10.8	135
450	11.4	170
500	12	155
600	13.2	155
700	14.4	215
800	15.6	130
900	16.8	205
1000	18	235
1200	20.4	248

DN	e	L
50	7	80
60	7	85
80	7	95
100	7.2	110
150	7.8	110
200	8.4	115
250	9	115
300	9.6	115
350	10.2	160
400	10.8	145
450	11.4	200
500	12	200
600	13.2	195
700	14.4	235
800	15.6	210
900	16.8	245
1000	18	275
1200	20.4	320

DN	e	L
50	7	150
60	7	160
65	7	165
80	7	130
100	7,2	140
125	7,5	150
150	7,8	160
200	8,4	180
250	9	245
300	9,6	275
350	10,2	300
400	10,8	325
450	11,4	350
500	12	375
600	13,2	425
700	14,4	480
800	15,6	530
900	16,8	580
1000	18	630
1100	19,2	695
1200	20,4	750
1400	22,8	775
1500	24	810
1600	25,2	845
1800	27,6	910
2000	30	980

Abresan Toloue Mehr Company reserves the right to change any dimension and specification to promote quality while considering related standards.

DOUBLE FLANGED 90° BEND & DOUBLE FLANGED DUCKFOOT 90° BEND

DOUBLE FLANGED 90° BEND

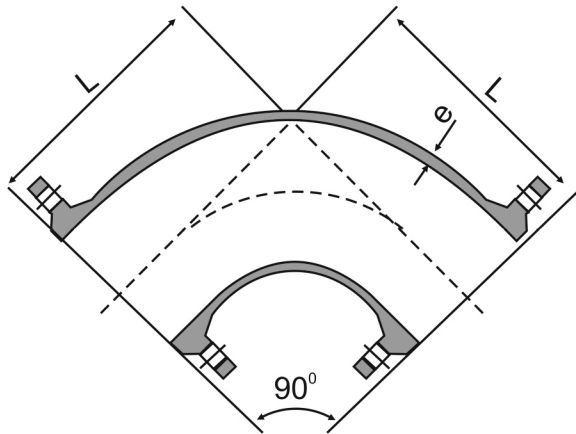

DOUBLE FLANGED DUCKFOOT 90° BEND

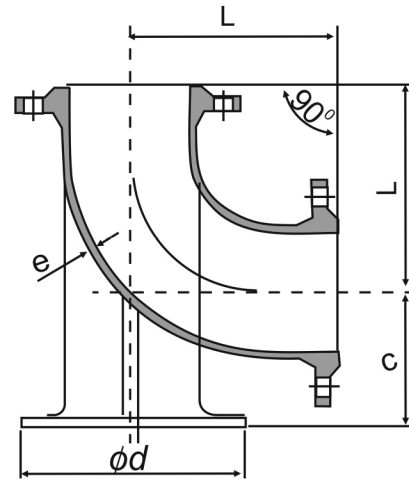

DN	A and B series				
	e	90° bends	90° duckfoot bends		
		L	L	c	d
50	7	150	150	95	150
60	7	160	160	100	160
65	7	165	165	100	165
80	7	165	165	110	180
100	7,2	180	180	125	200
125	7,5	200	200	140	225
150	7,8	220	220	160	250
200	8,4	260	260	190	300
250	9	350	350	225	350
300	9,6	400	400	255	400
350	10,2	450	450	290	450
400	10,8	500	500	320	500
450	11,4	550	550	355	550
500	12	600	600	385	600
600	13,2	700	700	450	700
700	14,4	800	—	—	—
800	15,6	900	—	—	—
900	16,8	1 000	—	—	—
1000	18	1 100	—	—	—

Abresan Toloue Mehr Company reserves the right to change any dimension and specification to promote quality while considering related standards.

DOUBLE FLANGED TAPER & ALL FLANGED

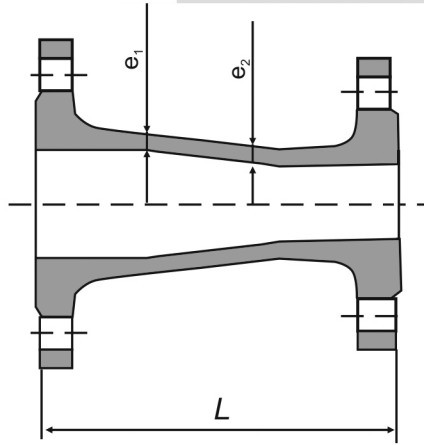

4head 4-way Flange

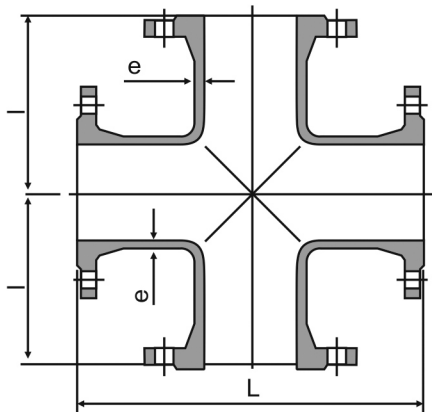

DN	dn	L	I	e
100	100	360	180	8.4
150	150	440	220	9.1
200	200	520	260	9.8
250	250	700	350	10.5
300	300	800	400	11.2
350	350	850	425	11.9
400	400	900	450	12.6
500	500	1000	500	14
600	600	1100	550	15.4
700	700	1200	600	16.8

4way connector pipe may be produced according to customer's order

Dnxdn	e ₁	e ₂	L
60x50	7	7	160
65x50	7	7	190
80x60	7	7	185
80x65	7	7	190
100x80	7,2	7	195
125x100	7,5	7,2	185
150x125	7,8	7,5	190
200x150	8,4	7,8	235
250x200	9	8,4	250
300x250	9,6	9	265
350x300	10,2	9,6	290
400x350	10,8	10,2	305
450x400	11,4	10,8	320
500x400	12	10,8	600
600x500	13,2	12	600
700x600	14,4	13,2	600
800x700	15,6	14,4	600
900x800	16,8	15,6	600
1000x900	18	16,8	600
1100x1000	19,2	18	600
1200x1000	20,4	18	790
1400x1200	22,8	20,4	850
1500x1400	24	22,8	695
1600x1400	25,2	22,8	910
1800x1600	27,6	25,2	970
2000x1800	30	27,6	1 030

Abresan Toloue Mehr Company reserves the right to change any dimension and specification to promote quality while considering related standards.

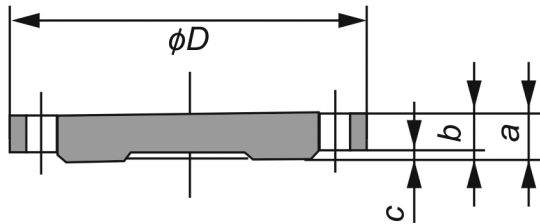

BLANK FLANGED

Dn	PN 10				PN 16			
	D	a	b	c	D	a	b	c
50	165	19	16	3	165	19	16	3
60	175	19	16	3	175	19	16	3
65	185	19	16	3	185	19	16	3
80	200	19	16	3	200	19	16	3
100	220	19	16	3	220	19	16	3
125	250	19	16	3	250	19	16	3
150	285	19	16	3	285	19	16	3
200	340	20	17	3	340	20	17	3
250	400	22	19	3	400	22	19	3
300	455	24,5	20,5	4	455	24,5	20,5	4
350	505	24,5	20,5	4	520	26,5	22,5	4
400	565	24,5	20,5	4	580	28	24	4
450	615	25,5	21,5	4	640	30	26	4
500	670	26,5	22,5	4	715	31,5	27,5	4
600	780	30	25	5	840	36	31	5
700	895	32,5	27,5	5	910	39,5	34,5	5
800	1 015	35	30	5	1 025	43	38	5
900	1 115	37,5	32,5	5	1 125	46,5	41,5	5
1000	1 230	40	35	5	1 255	50	45	5
1100	1 340	42,5	37,5	5	1 355	53,5	48,5	5
1200	1455	45	40	5	1485	57	52	5
1400	1675	46	41	5	1685	60	55	5
1500	1 785	47,5	42,5	5	1 820	62,5	57,5	5
1600	1 915	49	44	5	1 930	65	60	5
1800	2 115	52	47	5	2 130	70	65	5
2000	2 325	55	50	5	2 345	75	70	5

Abresan Toloue Mehr Company reserves the right to change any dimension and specification to promote quality while considering related standards.

GLAND & BOLTS & NUTS

SCREW AND NUT

MATERIAL : EN-GJS-400

COMPATIBILITY: DIN EN 1563

GLAND

Bolt			
DN	d	l	b
100-400	M20	90	50
500	M20	100	50
600	M20	100	60
700-800	M20	110	60
900	M20	120	60
1000	M24	120	60
1100*-1200	M24	130	60
1400-1500*	M30	155	70
1600-1800	M33	170	80
2000	M36	180	80

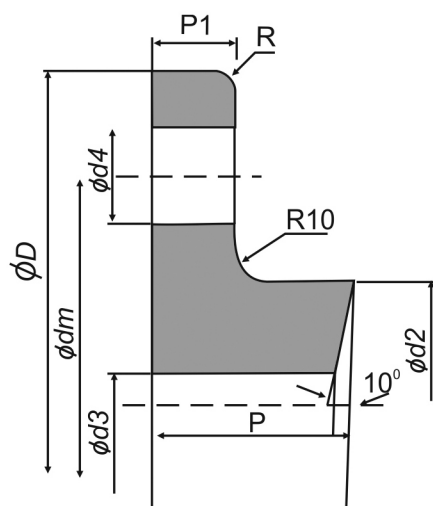
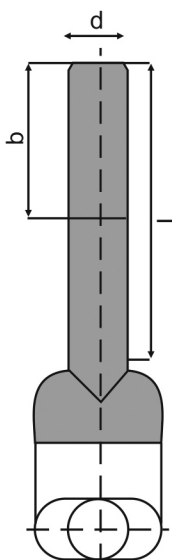

DN	D	dm	d2	d3	d4	P	P1	No. of Hole
80	210	167	128	105	36	20	5	4
100	232	189	147	125	37	20	5	4
150	287	243	199	177	39	21	5	6
200	343	298	251	229	41	22	5	6
250	399	353	303	281	42	23	5	8
300	356	409	357	334	44	24	5	8
350	513	466	409	386	46	25	5	12
400	570	520	459	436	48	26	5	12
500	680	630	567	537	51	28	7	16
600	790	740	672	640	54	30	7	16
700	900	850	777	742	56	31	7	20
800	1010	960	882	849	59	33	8	24
900	1125	1075	988	952	61	34	8	24
1000	1250	1190	1055	1055	63	35	8	30
1100	1350	1290	1210	1160	27	64	35	28
1200	1450	1390	1306	1263.3	27	66	36	28
1400	1700	1630	1516	1470.8	34	72	40	32
1500	1820	1730	1621.5	1574	34	75	42	32
1600	1930	1850	1727	1677.3	37	78	44	36
1800	2170	2080	1938	1884.8	37	84	48	40
2000	2400	2300	2150	2092.3	41	90	52	44

Abresan Toloue Mehr Company reserves the right to change any dimension and specification to promote quality while considering related standards.

FLANGED SOCKET (Bolted Gland) & COLLAR (Bolted gland)

FLANGED SOCKET (BOLTED GLAND)

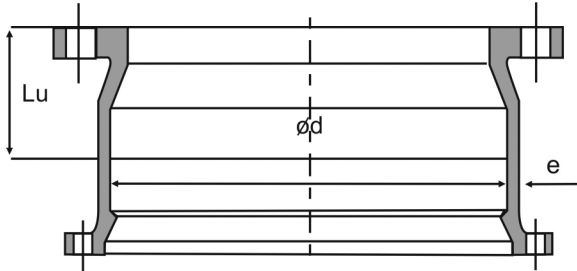

COLLAR (BOLTED GLAND)

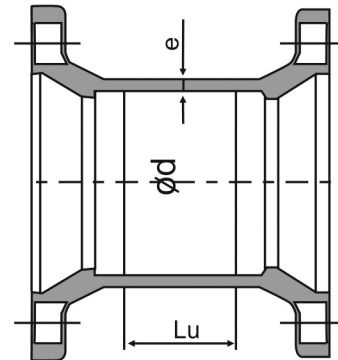

DN	e	d	Lu
80	7	109	130
100	7.2	130	130
150	7.8	183	135
200	8.4	235	140
250	9	288	145
300	9.6	340	150
350	10.2	393	155
400	10.8	445	160
500	12	550	170
600	13.2	655	180
700	14.4	760	190
800	15.6	865	200
900	16.8	970	210
1000	18	1075	220
1100	19.2	1180	230
1200	20.4	1285	240
1400	22.8	1495	310
1500	24	1598	330
1600	25.2	1701	330
1800	27.6	1907	350
2000	30	2113	370

DN	e	d	Lu
80	7	109	160
100	7.2	130	165
150	7.8	183	165
200	8.4	235	170
250	9	288	175
300	9.6	340	180
350	10.2	393	185
400	10.8	445	190
500	12	550	200
600	13.2	655	210
700	14.4	760	220
800	15.6	865	230
900	16.8	970	240
1000	18	1075	250
1100	19.2	1180	260
1200	20.4	1285	270
1400	22.8	1495	340
1500	24	1598	350
1600	25.2	1701	360
1800	27.6	1907	380
2000	30	2113	400

Abresan Toloue Mehr Company reserves the right to change any dimension and specification to promote quality while considering related standards.

DOUBLE SOCKET BEND (BOLTED GLAND)

**DOUBLE SOCKET BEND 22/5°
(BOLTED GLAND)**

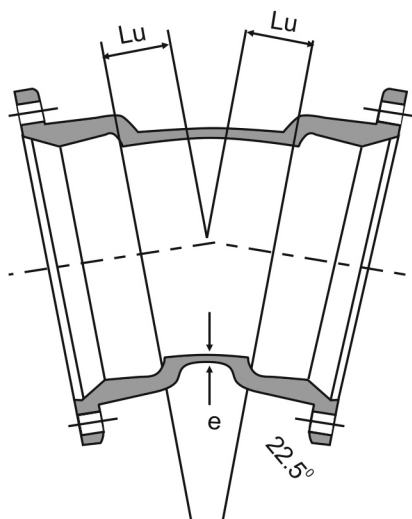

DN	e	Lu
80	7	40
100	7.2	40
150	7.8	55
200	8.4	65
250	9	75
300	9.6	85
350	10.2	95
400	10.8	110
500	12	130
600	13.2	150
700	14.4	175
800	15.6	195
900	16.8	220
1000	18	256
1100	19.2	260
1200	20.4	250
1400	22.8	260
1600	25.2	280

**DOUBLE SOCKET BEND 11/25°
(BOLTED GLAND)**

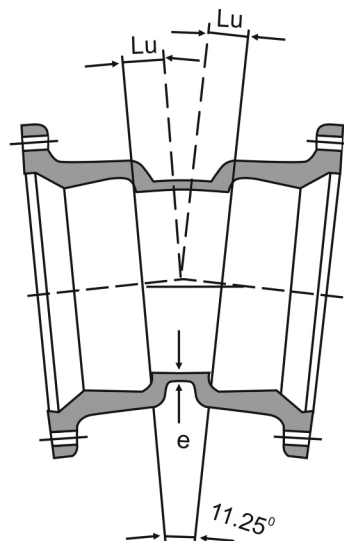

DN	e	Lu
80	7	30
100	7.2	30
150	7.8	35
200	8.4	40
250	9	50
300	9.6	55
350	10.2	60
400	10.8	65
500	12	75
600	13.2	85
700	14.4	95
800	15.6	110
900	16.8	120
1000	18	130
1100	19.2	140
1200	20.4	150
1400	22.8	165
1600	25.2	180

Abresan Toloue Mehr Company reserves the right to change any dimension and specification to promote quality while considering related standards.

DOUBLE SOCKET BEND (Bolted Gland)

DOUBLE SOCKET 90° BEND (BOLTED GLAND)

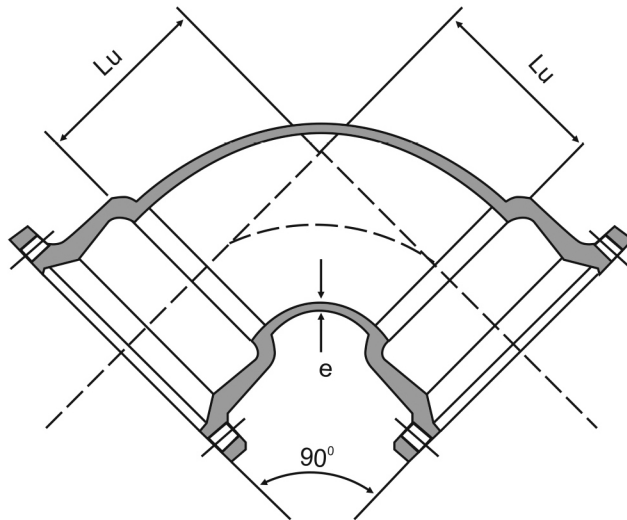

DOUBLE SOCKET 45° BEND (BOLTED GLAND)

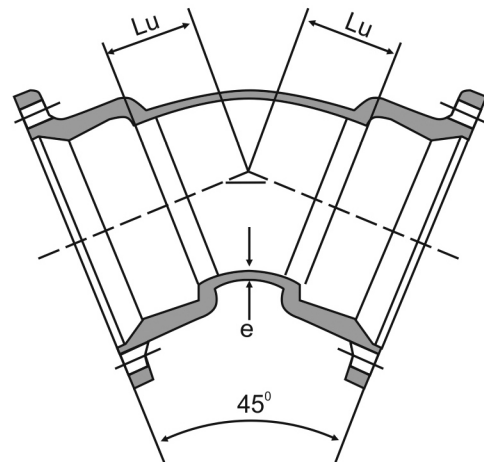

DN	e	Lu
80	7	100
100	7.2	120
150	7.8	170
200	8.4	220
250	9	270
300	9.6	320
350	10.2	370
400	10.8	420
500	12	554
600	13.2	647
700	14.4	741
800	15.6	839
900	16.8	935
1000	18	1029
1200	20.4	1220
1400	22.8	1220
1600	25.2	1290

DN	e	Lu
80	7	55
100	7.2	65
150	7.8	85
200	8.4	110
250	9	130
300	9.8	150
350	10.2	175
400	10.8	195
500	12	240
600	13.2	285
700	14.4	330
800	15.6	370
900	16.8	415
1000	18	464
1200	20.4	550
1400	22.8	515
1600	25.2	565

Abresan Toloue Mehr Company reserves the right to change any dimension and specification to promote quality while considering related standards.

DOUBLE SOCKET TEE WITH FLANGED BRANCH (Bolted Gland)

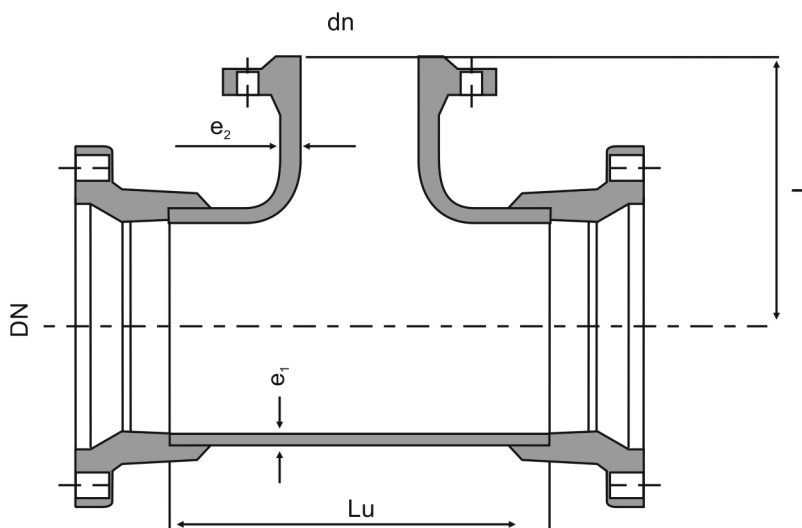

DN	dn	e ₁	e ₂	Lu	I
80	80	8.1	8.1	170	165
100	80	8.4	8.1	170	175
	100	8.4	8.4	190	180
150	80	9.1	8.1	170	205
	100	9.1	8.4	195	210
	150	9.1	9.1	255	220
200	80	9.8	8.1	175	235
	100	9.8	8.4	200	240
	150	9.8	9.1	255	250
	200	9.8	9.8	315	260
250	80	10.5	8.1	200	270
	100	10.5	8.4	200	270
	150	10.5	9.1	315	290
	200	10.5	9.8	315	290
	250	10.5	10.5	375	300
300	80	11.2	8.1	205	295
	100	11.2	8.4	205	300
	150	11.2	9.1	320	310

DN	dn	e ₁	e ₂	Lu	I
300	200	11.2	9.5	320	320
	250	11.2	10.5	435	330
	300	11.2	11.2	435	340
350	80	11.9	8.1	205	330
	100	11.9	8.4	205	330
	150	11.9	9.1	325	340
	200	11.9	9.8	325	350
	250	11.9	10.5	495	360
400	300	11.9	11.2	495	370
	350	11.9	11.9	495	380
	80	12.6	8.1	210	355
	100	12.6	8.4	210	360
	150	12.6	9.1	325	380
	200	12.6	9.8	325	380
	250	12.6	10.5	440	400
400	300	12.6	11.2	440	400
	350	12.6	11.9	560	410
	400	12.6	12.6	560	420

Abresan Toloue Mehr Company reserves the right to change any dimension and specification to promote quality while considering related standards.

DOUBLE SOCKET TEE WITH FLANGED BRANCH (Bolted Gland)

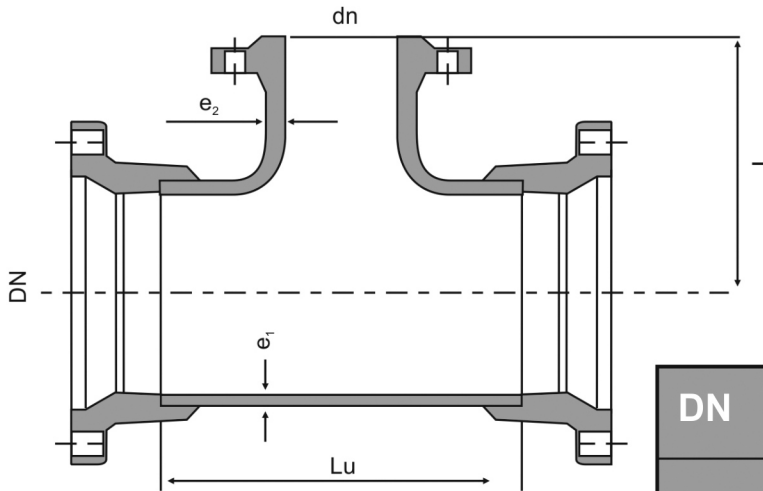

DN	dn	e ₁	e ₂	Lu	I
500	80	14	8.1	215	420
	100	14	8.4	215	420
	150	14	9.1	330	430
	200	14	9.8	330	440
	250	14	10.5	450	450
	300	14	11.2	450	460
	350	14	11.9	565	470
	400	14	12.6	565	480
	500	14	14	680	500
	600	80	15.4	8.1	340
100		15.4	8.4	340	480
150		15.4	9.1	340	490
200		15.4	9.8	340	500
250		15.4	10.5	570	510
300		15.4	11.2	570	520
350		15.4	11.9	570	530
400		15.4	12.6	570	540
500		15.4	14	800	560
600		15.4	15.4	800	580

DN	dn	e ₁	e ₂	Lu	I
700	80	16.8	8.1	345	500
	100	16.8	8.4	345	510
	150	16.8	9.1	345	520
	200	16.8	9.8	345	525
	250	16.8	10.5	575	530
	300	16.8	11.2	575	540
	350	16.8	11.9	575	550
	400	16.8	12.6	575	555
	500	16.8	16.8	925	570
	600	16.8	16.8	925	585
800	80	18.2	8.1	350	560
	100	18.2	8.4	350	570
	150	18.2	9.1	350	585
	200	18.2	9.8	350	585
	250	18.2	10.5	580	590
	300	18.2	11.2	580	600
	350	18.2	11.9	580	610
	400	18.2	12.6	580	615
	500	18.2	14	1045	630
	600	18.2	15.4	1045	645
700	18.2	16.8	1045	660	
800	18.2	18.2	1045	675	

Abresan Toloue Mehr Company reserves the right to change any dimension and specification to promote quality while considering related standards.

DOUBLE SOCKET TEE WITH FLANGED BRANCH (Bolted Gland)

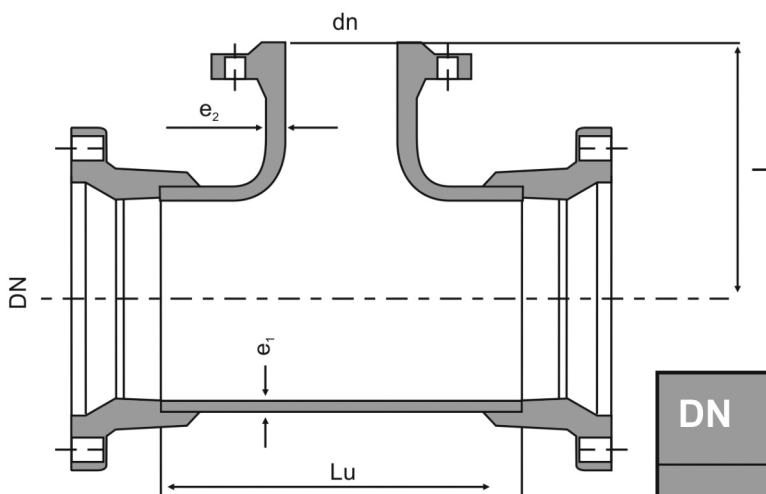

DN	dn	e ₁	e ₂	Lu	I
900	80	19.9	8.1	355	630
	100	19.6	8.4	355	630
	150	19.6	9.1	355	645
	200	19.6	9.8	355	645
	250	19.6	10.5	590	650
	300	19.6	11.2	590	660
	350	19.6	11.9	590	670
	400	19.6	12.6	590	675
	500	19.6	14	1170	690
	600	19.6	15.4	1170	705
	700	19.6	16.8	1170	725
	800	19.6	18.2	1170	735
900	19.6	19.6	1170	750	
1000	80	21	8.1	360	690
	100	21	8.4	360	690
	150	21	9.1	360	705
	200	21	9.8	360	705
	250	21	10.5	595	710
	300	21	11.2	595	720

DN	dn	e ₁	e ₂	Lu	I
1000	350	21	11.9	595	730
	400	21	12.6	595	735
	500	21	14	1290	750
	600	21	15.4	1290	765
	700	21	16.8	1290	780
	800	21	18.2	1290	795
	900	21	19.6	1290	810
1100	1000	21	21	1290	825
	200	22.4	9.8	370	765
	400	22.4	12.6	600	795
	600	22.4	15.4	830	825
	800	22.4	18.2	1065	855
	1000	22.4	21	1295	885
1200	1100	22.4	22.4	1410	900
	100	23.8	8.4	550	815
	200	23.8	9.8	550	825
	250	23.8	10.5	550	835
	300	23.8	11.2	605	845
	350	23.8	11.9	605	850
	400	23.8	12.6	605	855
	500	23.8	14	840	870
600	23.8	15.4	840	885	
700	23.8	16.8	955	900	

Abresan Toloue Mehr Company reserves the right to change any dimension and specification to promote quality while considering related standards.

DOUBLE SOCKET TEE WITH FLANGED BRANCH (Bolted Gland)

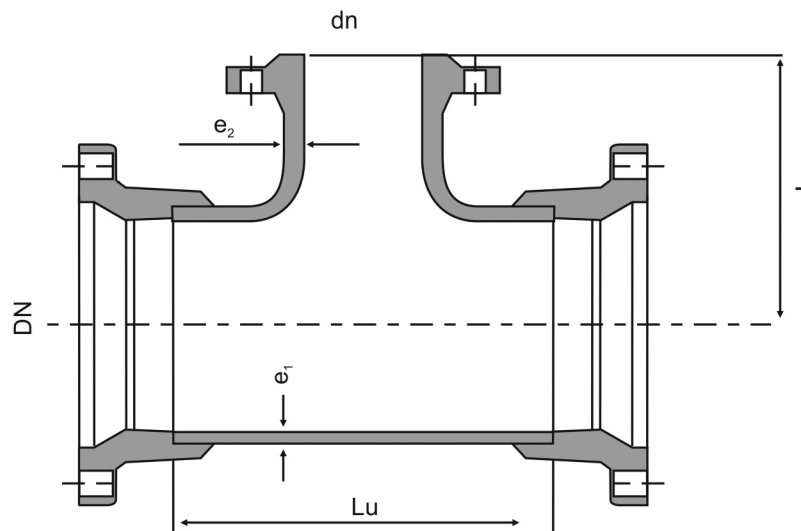

DN	dn	e ₁	e ₂	Lu	I
1200	800	23.8	18.2	1070	915
	900	23.8	19.6	1300	930
	1000	23.8	21	1300	945
	1200	23.8	23.8	1535	975
1400	200	26.6	9.8	800	925
	250	26.6	10.5	800	930
	300	26.6	11.2	800	935
	350	26.6	11.9	800	940
	400	26.6	12.6	800	950
	500	26.6	14	1030	975
	600	26.6	15.4	1030	980
	700	26.6	16.8	1260	995
	800	26.6	18.2	1260	1010
	900	26.6	19.6	1495	1025
	1000	26.6	21	1495	1040
	1200	26.6	23.8	1725	1070

DN	dn	e ₁	e ₂	Lu	I
1600	300	29.4	11.2	695	1045
	350	29.4	11.9	695	1050
	400	29.4	12.6	695	1060
	500	29.4	14	1040	1075
	600	29.4	15.4	1040	1090
	700	29.4	16.8	1275	1105
	800	29.4	18.2	1275	1120
	900	29.4	19.6	1505	1135
	1000	29.4	21	1505	1150
	1200	29.4	23.8	1740	1180
2000	1400	29.4	26.6	1970	1210
	1600	29.4	29.4	2200	1240
	1000	35	21	1530	1256
	1400	35	26.6	1995	1322
	1600	35	29.4	2225	1342

Abresan Toloue Mehr Company reserves the right to change any dimension and specification to promote quality while considering related standards.

FLANGED SOCKET (Tyton)

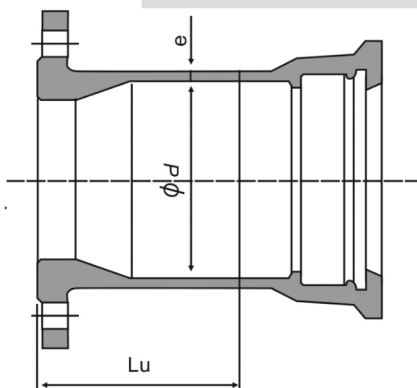

DN	e	L _u	d
80	7	105	109
100	7,2	110	130
125	7,5	115	156
150	7,8	120	183
200	8,4	120	235
250	9	125	288
300	9,6	130	340
350	10,2	135	393
400	10,8	140	445
450	11,4	145	498
500	12	170	550
600	13,2	180	655
700	14,4	190	760
800	15,6	200	865
900	16,8	210	970
1000	18	220	1 075
1100	19,2	230	1 180
1200	20,4	240	1 285
1400	22,8	310	1 477
1500	24	330	1 580
1600	25,2	330	1 683
1800	27,6	350	1 889
2000	30	370	2 095

Abresan Toloue Mehr Company reserves the right to change any dimension and specification to promote quality while considering related standards.

FLANGED SPIGOT & COLLAR (Tyton)

FLANGED SPIGOT

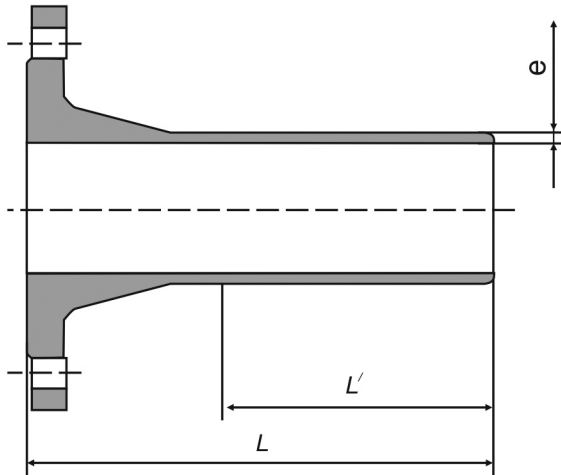

COLLAR (Tyton)

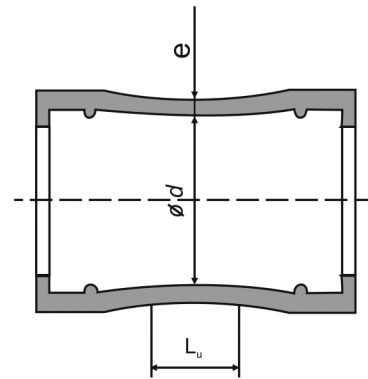

DN	e	Flanged spigots		Collars	
		L	L'	L _u	d
80	7	350	215	160	109
100	7,2	360	215	165	130
125	7,5	370	220	165	156
150	7,8	380	225	165	183
200	8,4	400	230	170	235
250	9	420	240	175	288
300	9,6	440	250	180	340
350	10,2	460	260	185	393
400	10,8	480	270	190	445
450	11,4	500	280	195	498
500	12	520	290	200	550
600	13,2	560	310	210	655
700	14,4	600	330	220	760
800	15,6	600	330	230	865
900	16,8	600	330	240	970
1000	18	600	330	250	1 075
1100	19,2	600	330	260	1 180
1200	20,4	600	330	270	1 285
1400	22,8	710	390	340	1 477
1500	24	750	410	350	1 580
1600	25,2	780	430	360	1 683
1800	27,6	850	470	380	1 889
2000	30	920	500	400	2 095

Abresan Toloue Mehr Company reserves the right to change any dimension and specification to promote quality while considering related standards.

DOUBLE SOCKET BEND (Tyton)

DOUBLE SOCKET BEND (Tyton) 11/25°

DOUBLE SOCKET BEND (Tyton) 22/5°

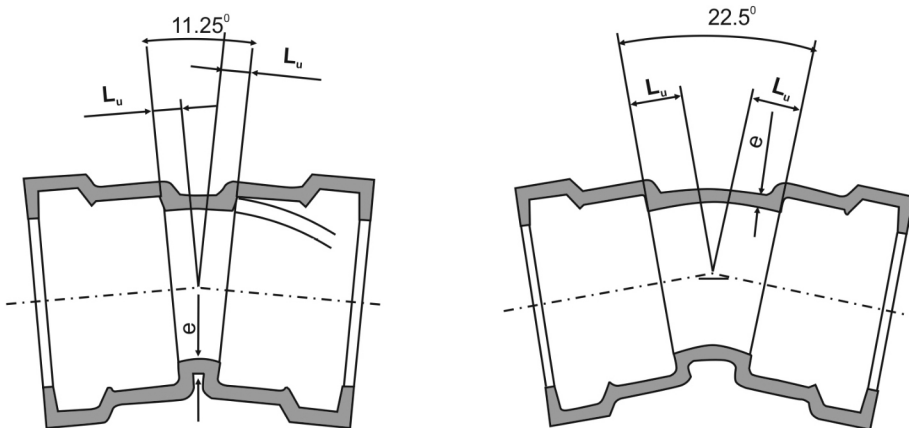

DN	e	L _u (11.25°)	L _u (22.5°)
80	7	30	40
100	7,2	30	40
125	7,5	35	50
150	7,8	40	55
200	8,4	45	65
250	9	55	75
300	9,6	55	85
350	10,2	60	95
400	10,8	65	110
450	11,4	70	120
500	12	75	130
600	13,2	85	150
700	14,4	95	175
800	15,6	110	195
900	16,8	120	220
1000	18	130	240
1100	19,2	140	260
1200	20,4	150	285
1400	22,8	130	260
1500	24	140	270
1600	25,2	140	280

Abresan Toloue Mehr Company reserves the right to change any dimension and specification to promote quality while considering related standards.

DOUBLE SOCKET BEND(Tyton)

DOUBLE SOCKET BEND (Tyton) 45°

DOUBLE SOCKET BEND (Tyton) 90°

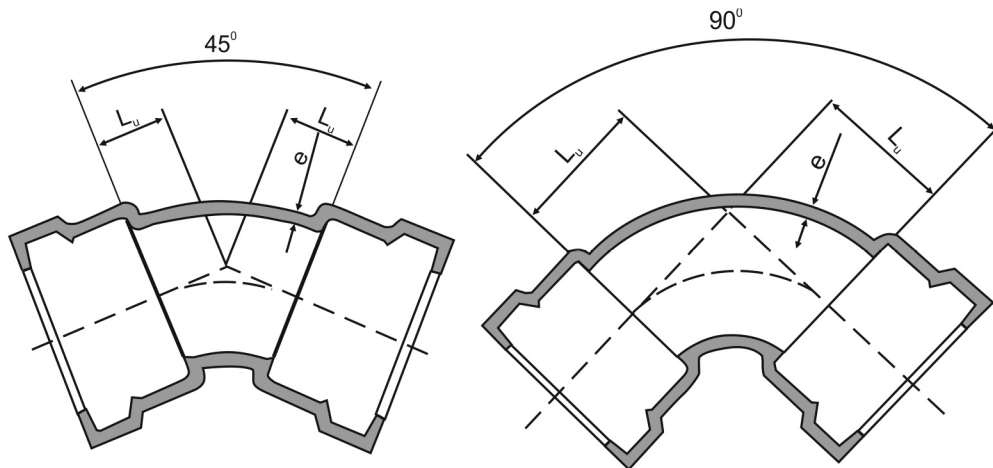

DN	e	L _u (45°)	L _u (90°)
80	7	50	85
100	7,2	60	100
125	7,5	65	115
150	7,8	70	130
200	8,4	80	160
250	9	135	240
300	9,6	155	280
350	10,2	170	370
400	10,8	185	420
450	11,4	200	554
500	12	220	554
600	13,2	240	647
700	14,4	285	741
800	15,6	330	839
900	16,8	370	935
1000	18	415	1029
1100	19,2	460	1200
1200	20,4	505	1220
1400	22,8	550	1250
1600	25,2	540	1290

Abresan Toloue Mehr Company reserves the right to change any dimension and specification to promote quality while considering related standards.

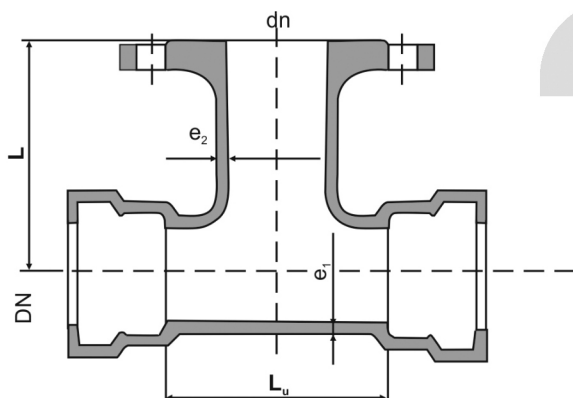

DOUBLE SOCKET TEE WITH FLANGED BRANCH (Tyton)

DOUBLE SOCKET TEE WITH FLANGED BRANCH (Tyton)

DN x dn	Body		Branch	
	e ₁	L _u	e ₂	L
80x80	7	175	7	165
100x50	7,2	155	7	145
100x60	7,2	155	7	165
100x80	7,2	165	7	170
100x100	7,2	195	7,2	180
125x50	7,5	155	7	160
125x60	7,5	155	7	180
125x80	7,5	175	7	185
125x100	7,5	195	7,2	195
125x125	7,5	225	7,5	200
150x50	7,8	160	7	170
150x60	7,8	160	7	190
150x80	7,8	180	7	200
150x100	7,8	200	7,2	205
150x125	7,8	230	7,5	215
150x150	7,8	260	7,8	220
200x50	8,4	165	7	195
200x60	8,4	165	7	215
200x80	8,4	180	7	225
200x100	8,4	200	7,2	230
200x125	8,4	235	7,5	240
200x150	8,4	260	7,8	245
200x200	8,4	320	8,4	260
250x60	9	165	7	260
250x80	9	185	7	265
250x100	9	205	7,2	270
250x150	9	265	7,8	280
250x200	9	320	8,4	290
250x250	9	380	9	300

Abresan Toloue Mehr Company reserves the right to change any dimension and specification to promote quality while considering related standards.

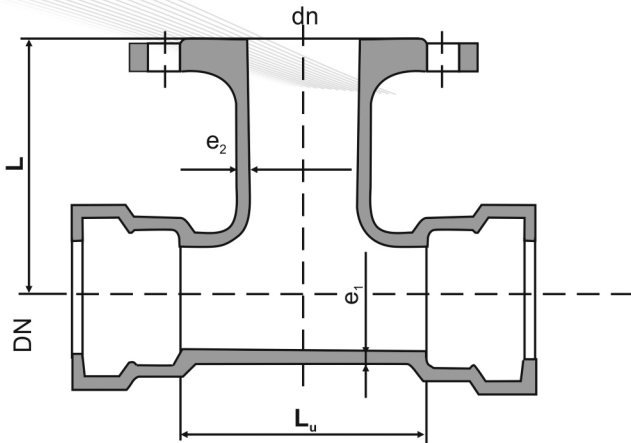

DOUBLE SOCKET TEE WITH FLANGED BRANCH (Tyton)

DOUBLE SOCKET TEE WITH FLANGED BRANCH (Tyton)

DN x dn	Body		Branch	
	e ₁	L _u	e ₂	L
800X200	15,6	350	8,4	585
800x400	15,6	580	10,8	615
800x600	15,6	1 045	13,2	645
800x800	15,6	1 045	15,6	675
900x200	16,8	355	8,4	645
900x400	16,8	590	10,8	675
900x600	16,8	1 170	13,2	705
900x900	16,8	1 170	16,8	750
1000x200	18	360	8,4	705
1000x400	18	595	10,8	735
1000x600	18	1290	13,2	765
1000x1000	18	1290	18	825
1100x400	19,2	600	10,8	795
1100x600	19,2	830	13,2	825
1200x600	20,4	840	13,2	885
1200x800	20,4	1 070	15,6	915
1200x1000	20,4	1 300	18	945
1400x600	22,8	1 030	13,2	980
1400x800	22,8	1 260	15,6	1 010
1400x1000	22,8	1 495	18	1 040
1500x600	24	1 035	13,2	1 035
1500x1000	24	1 500	18	1 595
1600x600	25,2	1 040	13,2	1 090
1600x800	25,2	1 275	15,6	1 120
1600x1000	25,2	1 505	18	1 150
1600x1200	25,2	1 740	20,4	1 180
1800x600	27,6	1 055	13,2	1 200
1800x800	27,6	1 285	15,6	1 230
1800x1000	27,6	1 520	18	1 260
1800x1200	27,6	1 750	20,4	1 290
2000x600	30	1 065	13,2	1 310
2000x1000	30	1 530	18	1 370
2000x1400	30	1 995	22,8	1 430

DN x dn	Body		Branch	
	e ₁	L _u	e ₂	L
300x60	9,6	165	7	290
300x80	9,6	185	7	295
300x100	9,6	210	7,2	300
300x150	9,6	265	7,8	310
300x200	9,6	325	8,4	320
300x250	9,6	380	9	330
300x300	9,6	440	9,6	340
350x60	10,2	170	7	320
350x80	10,2	185	7	325
350x100	10,2	210	7,2	330
350x150	10,2	270	7,8	340
350x200	10,2	325	8,4	350
350x250	10,2	385	9	360
350x350	10,2	500	10,2	380
400x80	10,8	190	7	355
400x100	10,8	210	7,2	360
400x150	10,8	270	7,8	370
400x200	10,8	330	8,4	380
400x250	10,8	385	9	390
400x300	10,8	445	9,6	400
400x400	10,8	560	10,8	420
450x100	11,4	215	7,2	390
450x150	11,4	270	7,8	400
450x200	11,4	330	8,4	410
450x250	11,4	390	9	420
450x300	11,4	445	9,6	430
450x400	11,4	560	10,8	450
450x450	11,4	620	11,4	460
500x100	12	215	7,2	420
500x200	12	330	8,4	440
500x400	12	565	10,8	480
500x500	12	680	12	500
600x200	13,2	340	8,4	500
600x400	13,2	570	10,8	540
600x600	13,2	800	13,2	580
700x200	14,4	345	8,4	525
700x400	14,4	575	10,8	555
700x700	14,4	925	14,4	600

Abresan Toloue Mehr Company reserves the right to change any dimension and specification to promote quality while considering related standards.